

- \* Overall Options\***
- Line control
  - switched power outlet
  - Led trailer detection
  - Double rubber side flaps
  - custom options

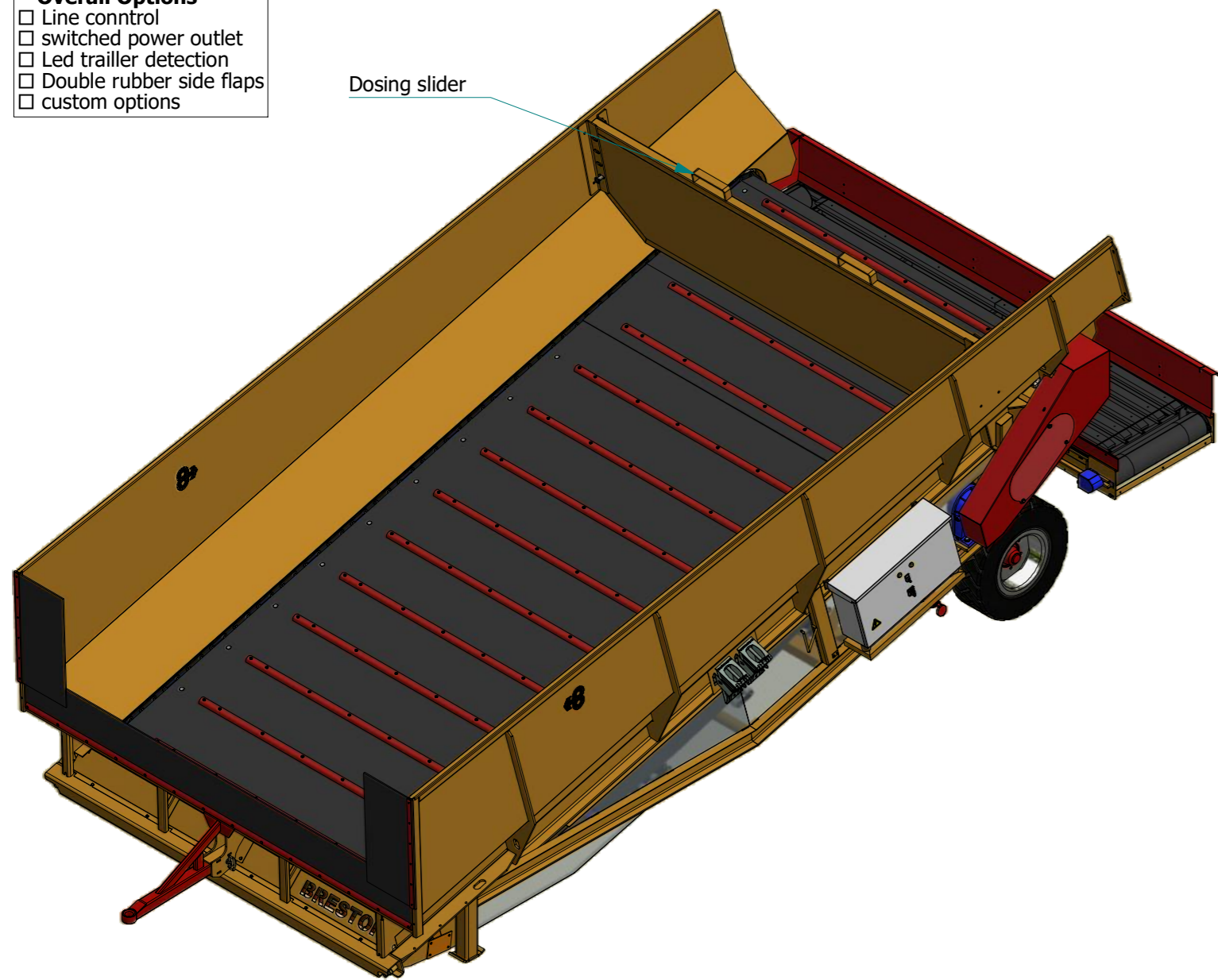

Dosing slider

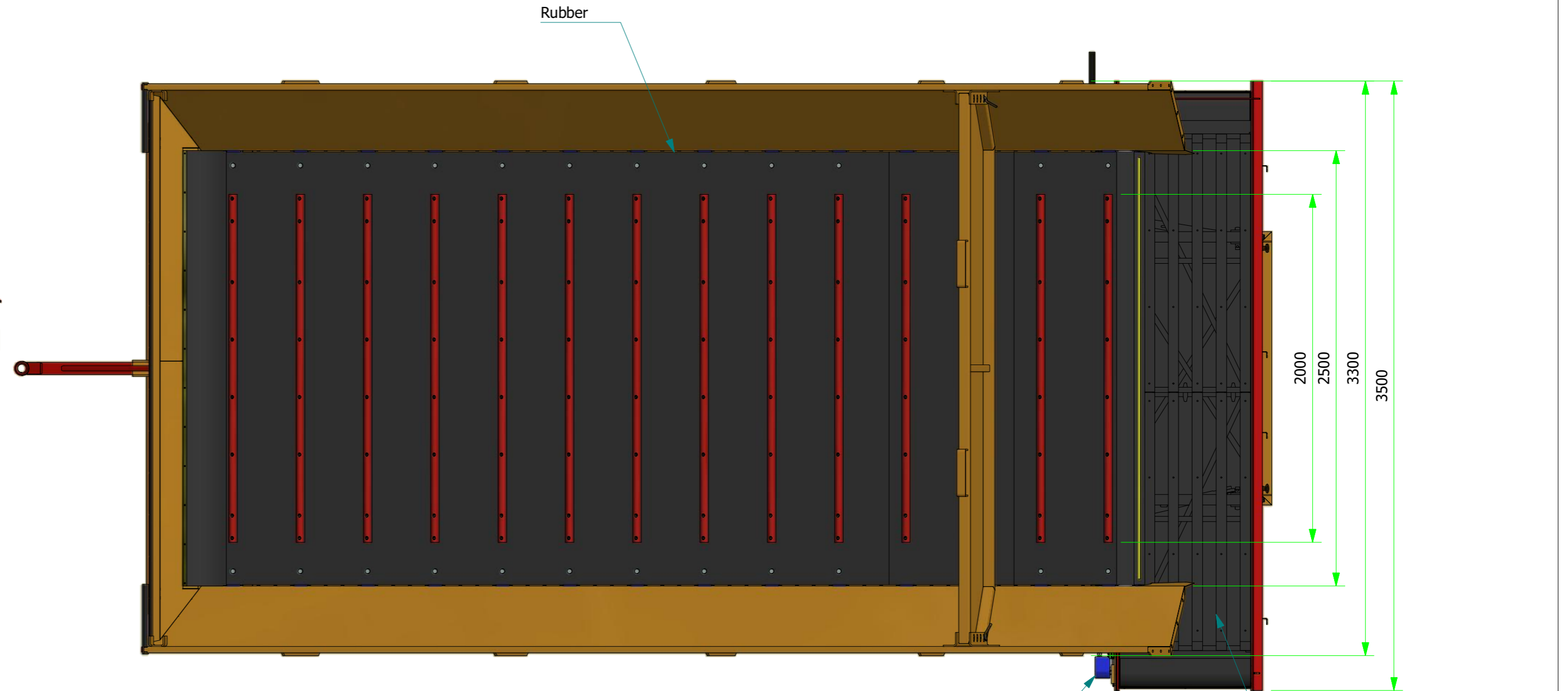

Rubber

- HDPE Impact bars (no moving parts)  
 \*Optional\*
- Plastic Rollers
  - Steel Rollers
  - Stainless steel Rollers

Types of NB10-250 Hoppers	
Hopper Type	Hopper Length
A	5,0m
B	5,5m
C	6,0m
D	6,5m
E	7,0m
F	7,5m
G	8,0m
H	8,5m
I	9,0m
J	9,5m
K	10,0m

- Variable floor speed control  
 5-75Hz
- Standard: 0,27-4,1m/min**
  - Slow: 0,22-3,23m/min
  - Fast: 0,48-7,19m/min

2,2kW 1,15m/s belt drive

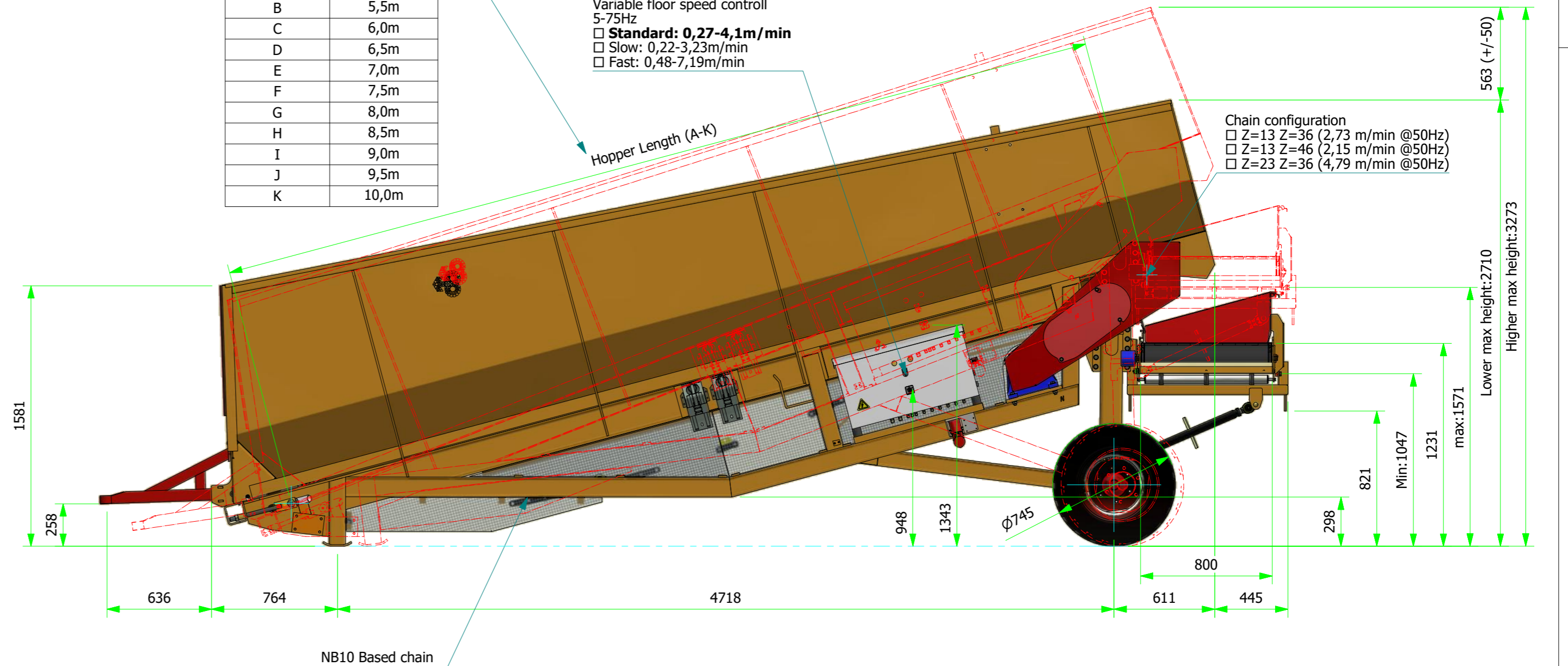
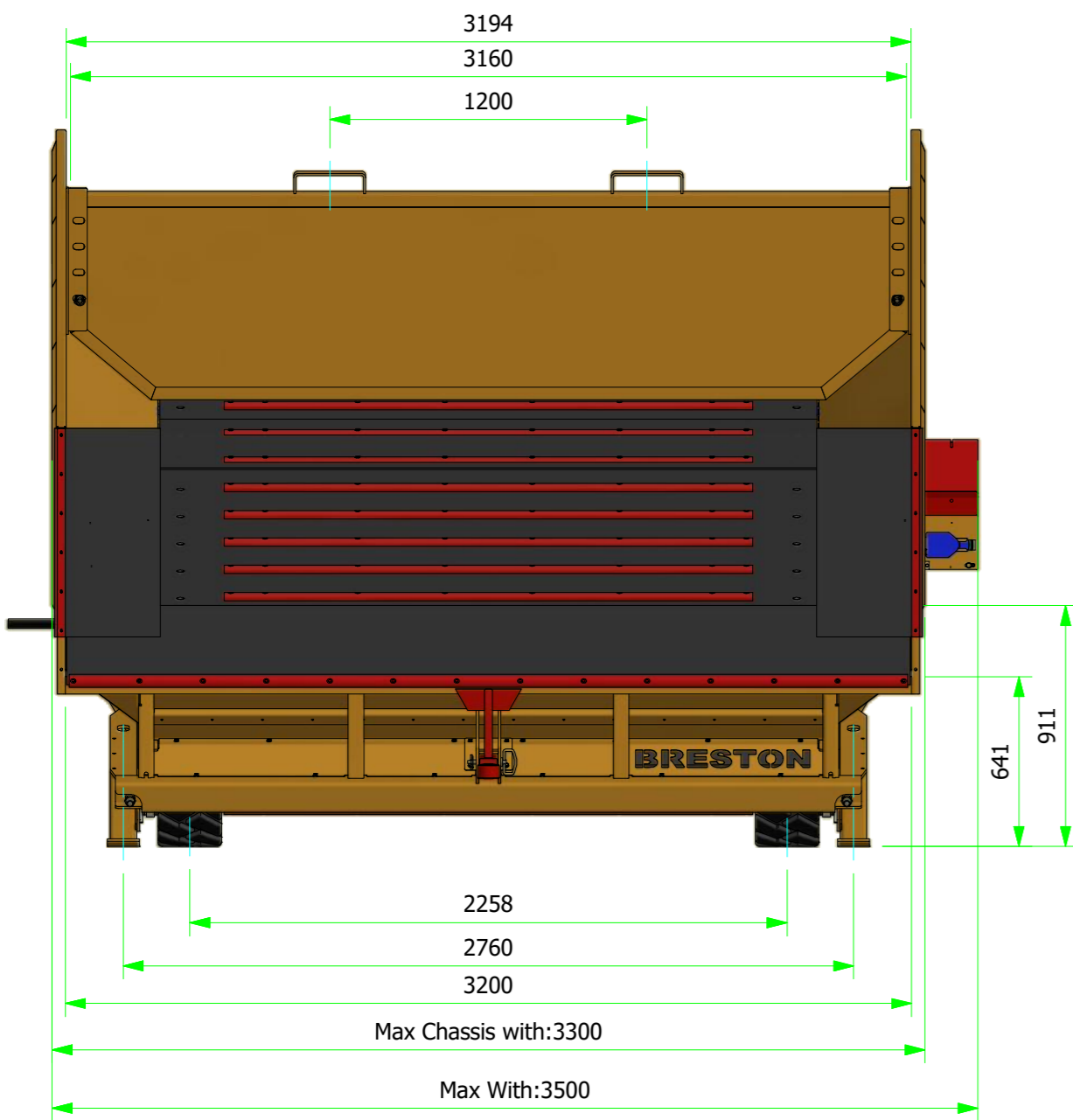

- Chain configuration
- Z=13 Z=36 (2,73 m/min @50Hz)
  - Z=13 Z=46 (2,15 m/min @50Hz)
  - Z=23 Z=36 (4,79 m/min @50Hz)

NB10 Based chain



Benaming: NB10-250A-K Hopper

Opmerking: RECEIVING HOPPER NB10-250A-K

Get.: 1 : 25 A2  
 Datum:

Ordernummer:  
 Opdrachtgever:  
 Tekeningsnummer:  
 Rev.: